



Idaho National Laboratory

Modeling the GFR with RELAP5-3D

C. B. Davis, T. D. Marshall, and K. D. Weaver

September 7-9, 2005

Outline

- **Introduction**
- **Code improvements**
- **Verification and validation**
- **Development of the input model**
- **Results**

Introduction

- **The Gas Fast Reactor (GFR) has been chosen as one of six Generation IV systems to be evaluated based on sustainability, economics, safety and reliability, and proliferation resistance and physical protection**
- **Significant improvements have been made to RELAP5/ATHENA to model the GFR**
- **The improved code version was used to develop a model of the power conversion unit (PCU)**
- **The PCU was coupled to a model of the reactor vessel and the combined model used to simulate two transients, one initiated by a reactor trip and the other by a loss of load**
- **The remainder of this presentation describes these items in more detail**

The GFR utilizes supercritical CO₂ in a direct Brayton cycle

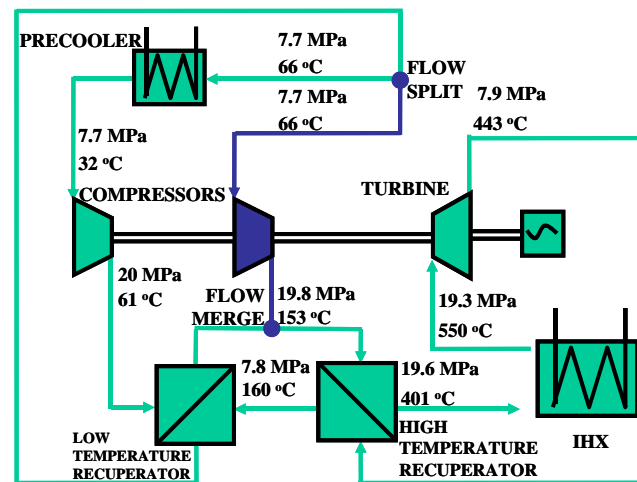
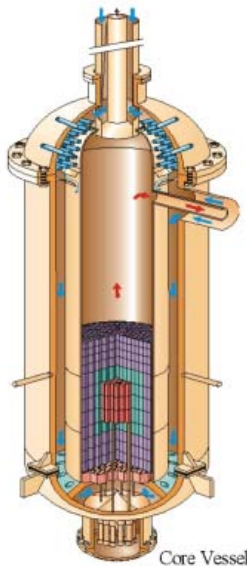

- Supercritical CO₂ cycle developed by MIT
- Achieves high thermal efficiency (~45%) with a modest reactor outlet temperature (550 °C)

Significant improvements have been made to RELAP5/ATHENA

- **CO₂ properties have been added to the code**
- **The turbine model has been enhanced**
- **A compressor model has been developed**
- **The Gnielinski forced convection heat transfer correlation has been added as a user option**
 - **Represents entrance effects, heated wall effects, and the transition between turbulent and laminar flow**
 - **Equally applicable to both liquid and gas coolants**

CO₂ properties were added to the code to support analyses of the GFR

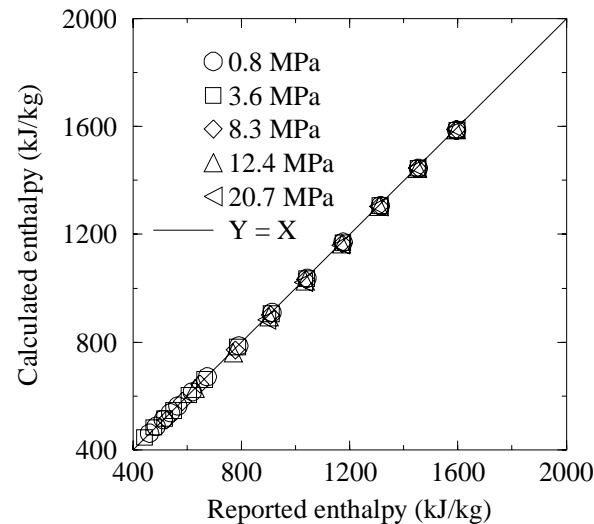
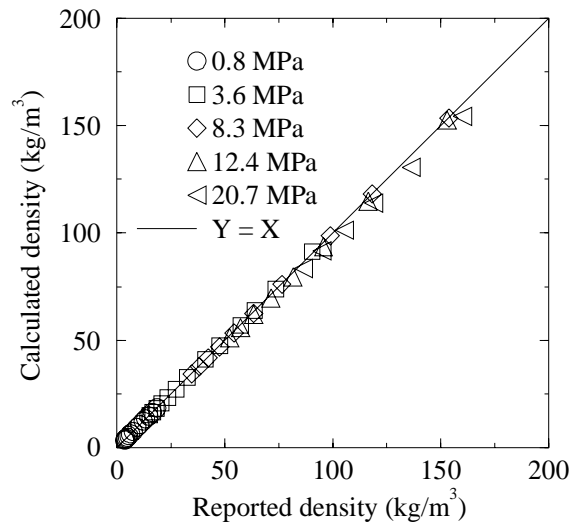

- Properties based on NIST database
- Properties validated using independent sources of data

The turbine model was enhanced

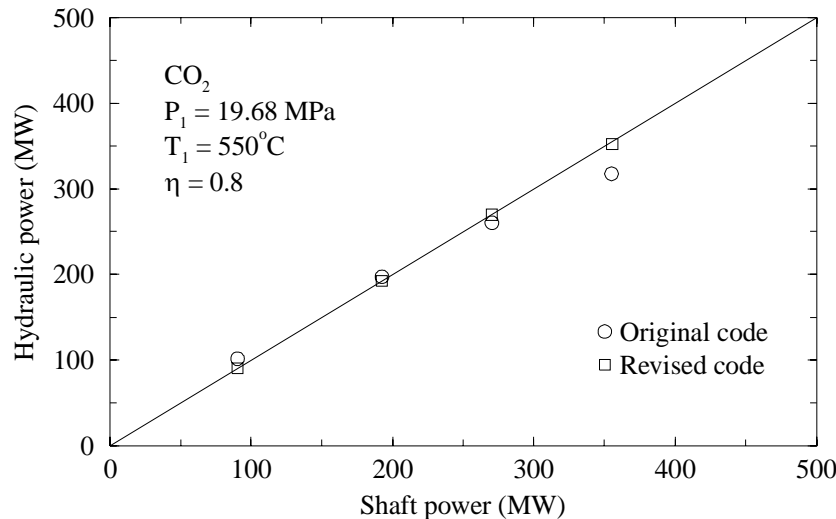

- The power added to the shaft is now consistent with the power removed from the fluid
- The flexibility of the model was increased by adding variable frictional torque, variable moment of inertia, and a new type of turbine that allows the user to specify efficiency as a function of speed and load

A RELAP5/ATHENA model of the GFR system was developed

- **The models of the reactor vessel and the Reactor Cavity Cooling System were based on existing models**
- **A model of the GFR PCU was developed**
 - **Contains one turbine, two compressors, two recuperators, and a precooler**
 - **The component models were validated against MIT design calculations**

The turbine model agreed reasonably well with MIT design calculations

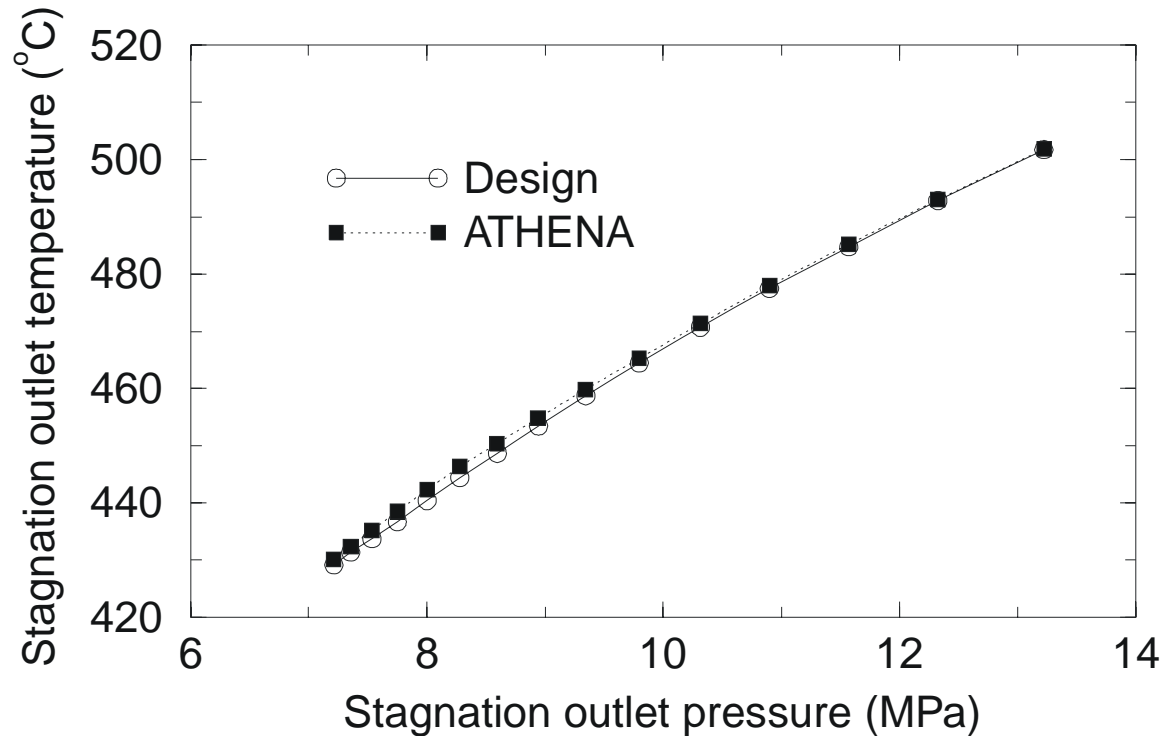

The compressor model agreed reasonably well with MIT design calculations

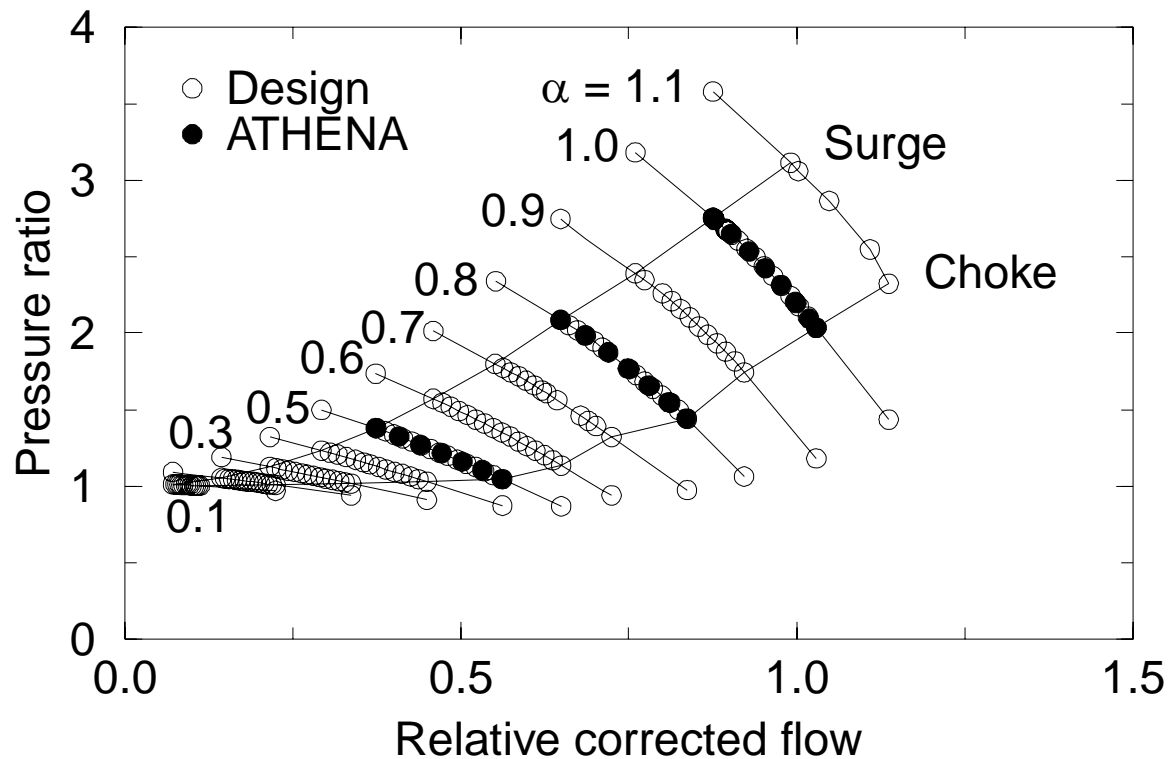

- The model was compared with design calculations at three different speeds
- Operation is physically allowed only between the surge and choke lines
- Input curves were extrapolated so that the entire range of allowed operation could be simulated

The PCU model simulates all three compact heat exchangers

- Each component represents a printed circuit heat exchanger of the type manufactured by Heatric
 - Contains millions of small semi-circular channels that are arranged in layers
- One-dimensional heat conduction in a rectangular geometry was used to represent the actual (multi-dimensional) heat conduction
- Relatively detailed nodalizations (20 to 40 control volumes) were required to match MIT design calculations

The PCU model represents the design reasonably well at steady state

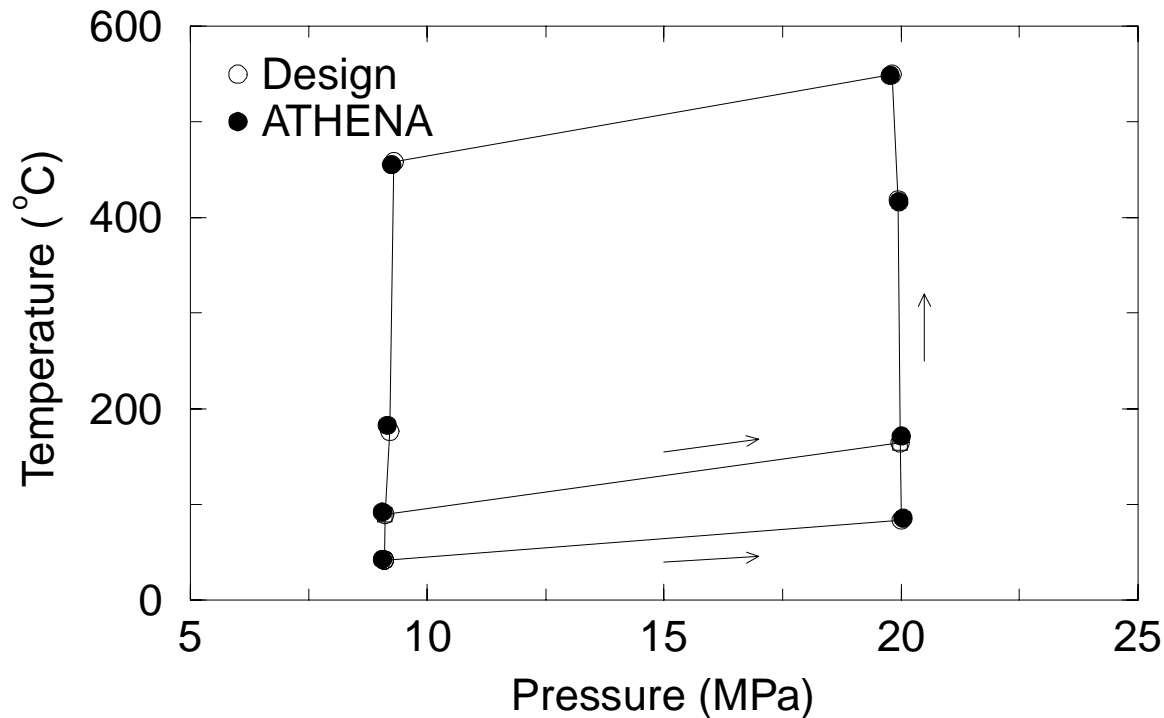

- Calculated results are within a few percent of the design values

The GFR model was used to simulate a reactor trip

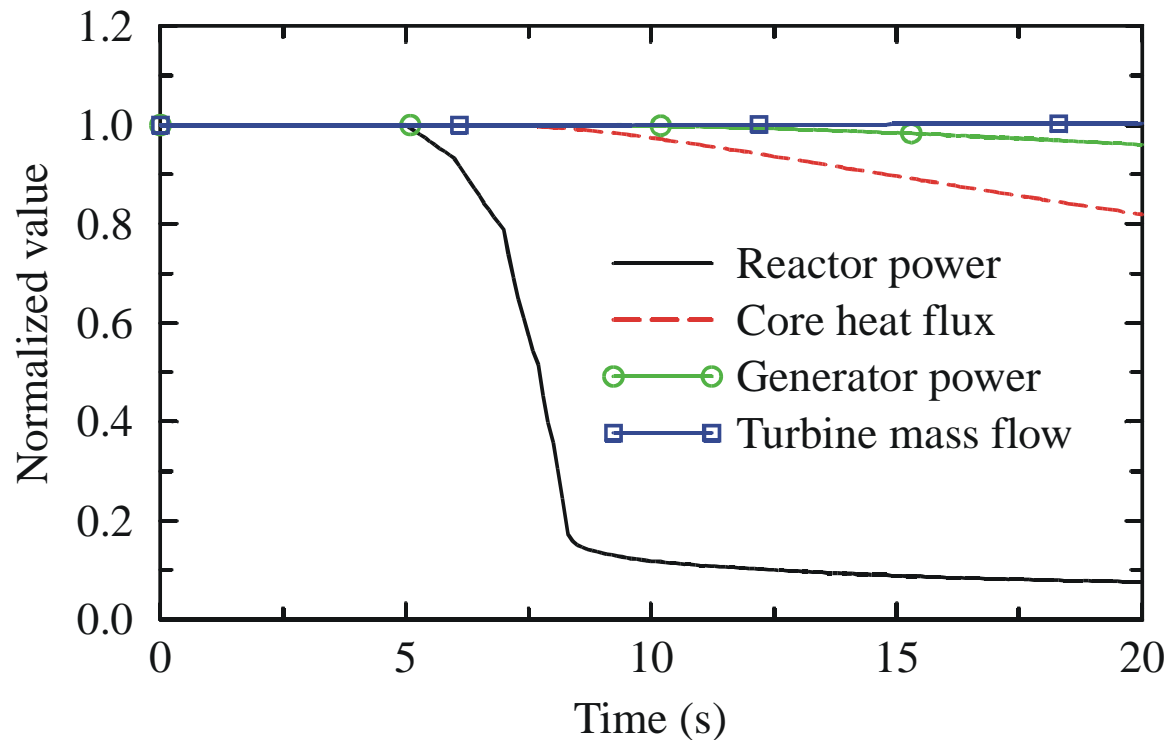

- Reactor trip was initiated at 5.0 s
- Normalized values are presented
- The reactor continued to supply power to the generator because of the large thermal capacitance of the fuel blocks

The GFR model was used to simulate a reactor trip (cont'd)

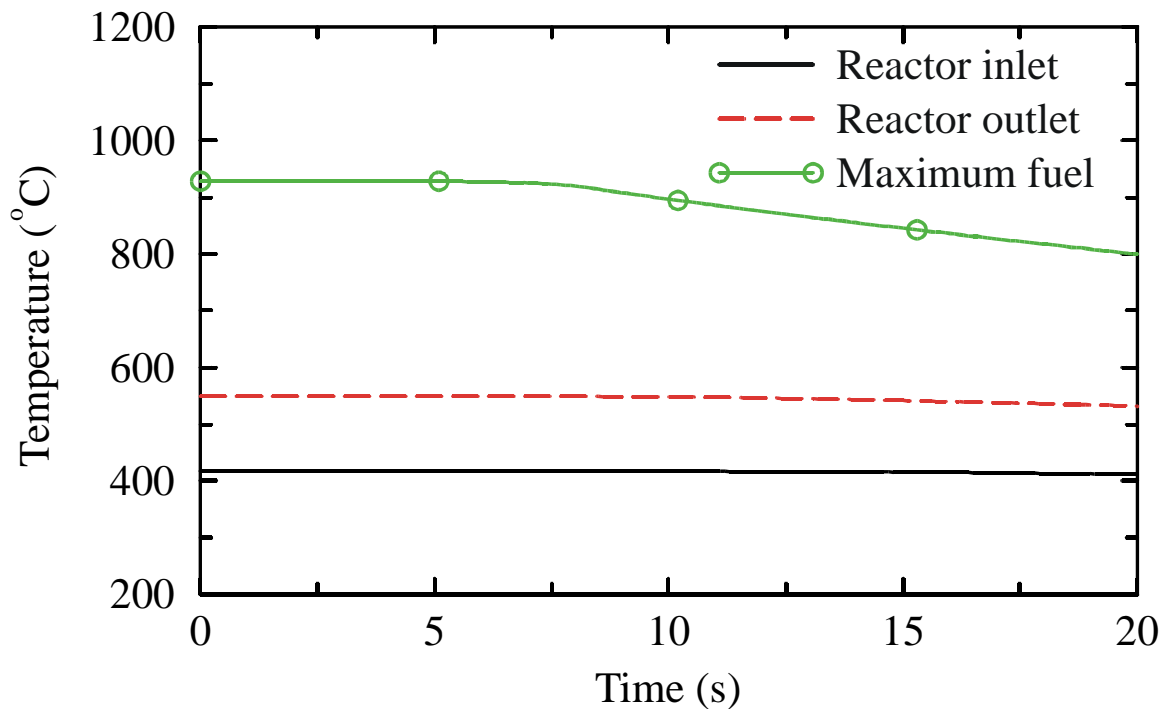

- The maximum fuel temperature decreased slowly because of the large thermal capacitance of the fuel blocks

The GFR model was used to simulate a loss of external load

- This event decouples the generator from the external power grid, which causes the shaft speed to increase**
- Control systems will be developed to protect the turbomachinery but have not been designed and were not modeled here**
- Preliminary calculations with the compressor model quickly exceed the speed range supplied by MIT**
- Because of the large extrapolation required to simulate this event, the compressor was simulated with a centrifugal pump**

The homologous pump parameters represented the compressors fairly well

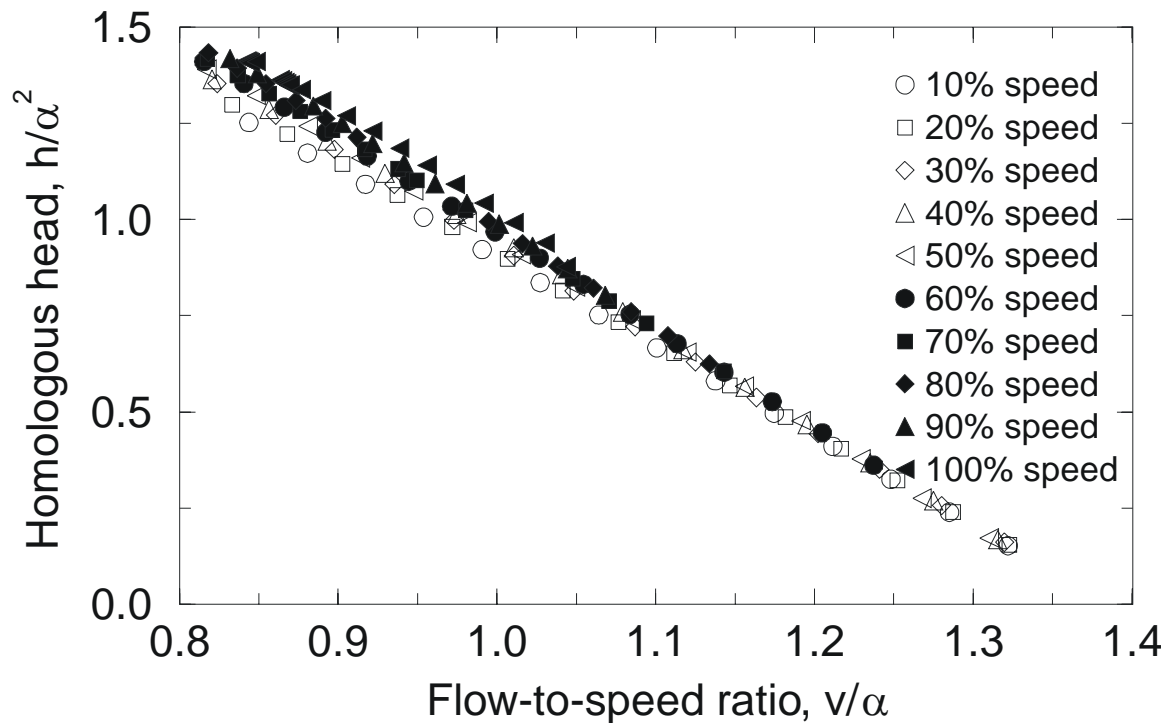

- The volumetric flow was computed using the average density
- The scatter increased significantly when either the inlet or outlet density was used
- Less scatter was obtained for the recompressing compressor, probably because it operated farther away from the critical point

The loss of load caused a rapid increase in shaft speed

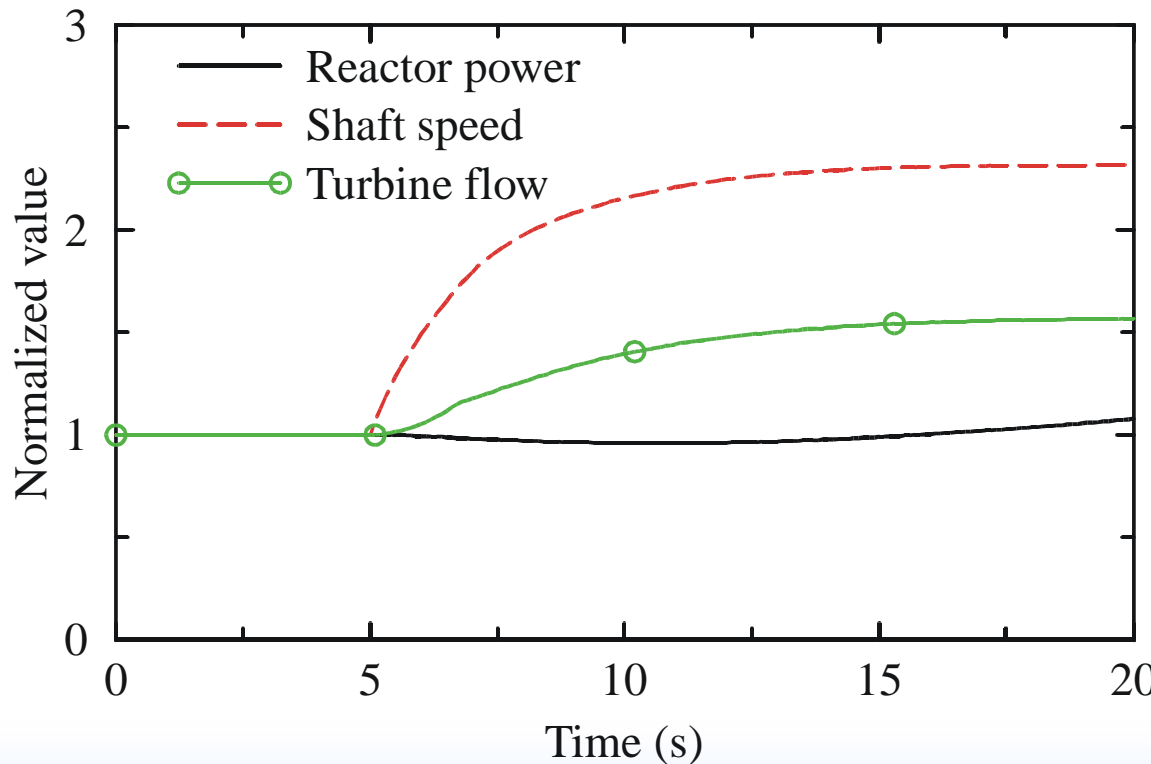

- Causes concern about the structural integrity of the turbomachinery
- Results are preliminary because of the lack of a control system, uncertainty regarding the moments of inertia, and the lack of compressor performance curves at high speeds

Higher fuel temperatures were obtained with the Gnielinski correlation

- The Dittus-Boelter correlation predicts heat transfer coefficients that are about 10% too high for helium gas with small temperature differences between the wall and the bulk fluid (from Volume 4 of the code manual)
- Gnielinski recommends a correction factor to account for large temperature differences (such as occur in the GFR)
- The Gnielinski correlation predicted a 20% reduction in the heat transfer coefficient compared to Dittus-Boelter during normal operation
 - Maximum fuel temperatures were 79 K higher
 - The Gnielinski correlation is expected to be more accurate for the GFR than the Dittus-Boelter correlation

Conclusions

- **Significant improvements have been made to RELAP5/ATHENA for the simulation of the GFR**
- **Comparisons of the system model and design calculations indicate that the model represents the PCU reasonably well at steady state**
- **Analysis indicates that the control system does not have to respond quickly to protect the turbomachinery following a reactor trip**

Conclusions (cont'd)

- **A loss of external load results in a rapid overspeed of the shaft with the potential to damage the turbomachinery**
 - **Although the results are considered preliminary, the control system will have to respond quickly during this transient**
- **The Gnielinski correlation should be more accurate than the Dittus-Boelter correlation for the conditions expected in the GFR**